

GMB75 Monitor

Angus Hi-Combat GMB75 Monitor
Nominal Flow : 7570 litres/min
 P/No. MA259070

- Simple and reliable design
- Low maintenance
- Ideal for Industrial, offshore and other marine applications
- Suitable for use where explosive atmospheres may be present



The Angus GMB75 fire monitor is a simple and reliable design with non-reversible worm and wheel gearbox control in both the horizontal and vertical plane. Movement is controlled by dual hand wheels.

Using balanced reaction forces and smooth effortless geared operation, the monitor allows the extinguishing medium to be accurately targeted wherever and whenever required. The GMB75 is engineered for exceptional operational reliability, long life and is maintenance free.

It is produced using only high grade corrosion resistant materials including brass, and stainless steel.

Computer designed guide vanes cast into the body reduce turbulence and spin in the water stream lowering pressure loss and improving jet reach.

All Angus monitors are based on a proven low maintenance design.

The standard nozzle recommended for the GMB75 monitor is the Angus Hi Combat 837-BC (pictured). See separate data sheet for details.

Body materials

Brass body (UNS C83600, ASTM B62), features full 4 inch waterway.

Bearing materials

Stainless steel double ball race bearings on both axis ensure smooth movement through vertical and horizontal plane.

Worm gear is fully enclosed to protect from the elements.

Monitor is red powder coated finished to maximise corrosion resistance..

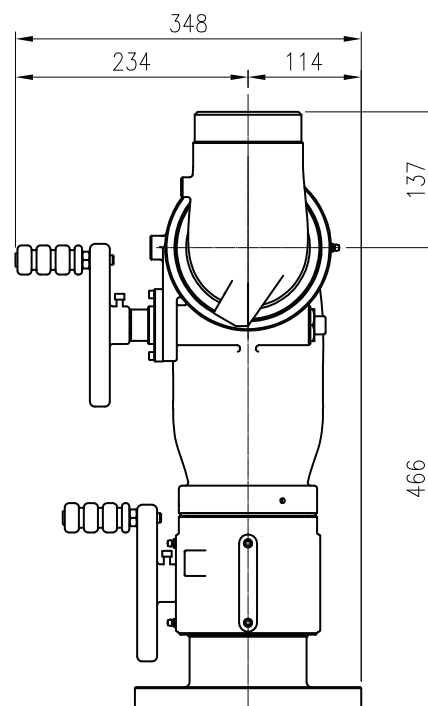
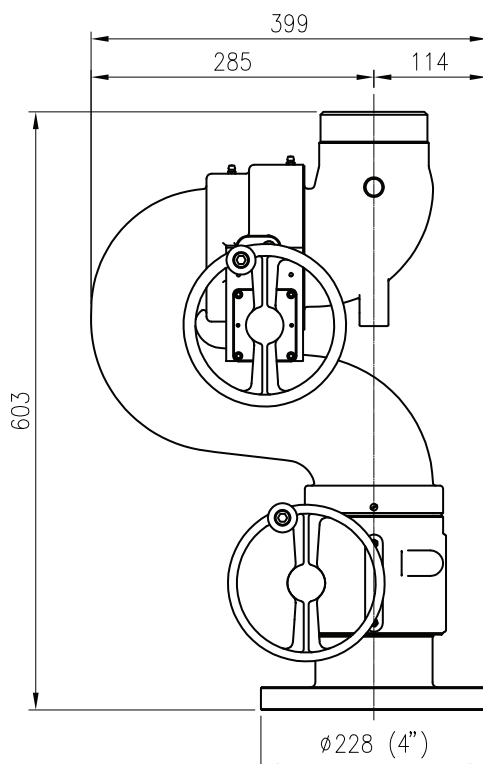

GMB75 Monitor

Angus Hi-Combat GMB75 Monitor Nominal Flow : 7570 litres/min

Optional Inlet Flanges:

ASA, DIN or ISO to special order.

Optional Outlet:

NH/NST.

Pressure loss

2.62 bar g @ 7570 litres/min

1.03 bar g @ 4542 litres/min

Movement

360° continuous rotation in the horizontal plane.

+90° / -45° movement in the vertical plane..

Specification	
Operating pressure	Min: 5 bar g (72psi), Max: 14 bar g (203psi)
Test pressure	34 bar g (493psi)
Maximum flow	7,570 litres/min (2000 USGPM)
Inlet flange connection	4" ANSI Class 150 (6" alternative to special order)
Outlet connections	3½" BSP Male
Monitor Body	Brass (UNS C83600, ASTM B62)
Bearings	Stainless Steel
Approx. weight (without nozzle/cannon)	55 kg

All monitors from Angus Fire are designed to be compact with a low profile.

Angus Fire is assessed to ISO 9001.

Angus Fire Ltd

Station Road, Bentham, Lancaster, LA2 7NA, UK
Tel: +44 (0)1524 264000 • Fax: +44 (0)1524 264180

Angus Fire operates a continuous programme of product development. The right is therefore reserved to modify any specification without prior notice and Angus Fire should be contacted to ensure that the current issues of all technical data sheets are used.