

# Tartan Pressure Regulating Valves

**Bib-nosed type**

**MT-451415**

**MT-451416**

**MT-451428**

**Manufactured and approved to BS5041-1 1987**



## Common features

- Construction and performance in accordance with BS5041 part 1 1987
- Material - Main body and outlet connection LG2 BS1400 Gunmetal
- Inlet connection - Flange or Threaded (see below)
- Outlet connection 65 mm (2.5") Female Instantaneous to BS336
- Working Pressure 20 bar , between temperature range 0°C to 38°C
- Seat Test Pressure 22 bar, Body Test Pressure 30 bar
- Static Outlet Pressure Range 5 - 8 bar
- Supplied with Male BS336 Blank Plug & Chain
- Handwheel in Grey Cast iron, black painted finish
- Flow Rate @ 7 Bar approximately 8.5 litres per second
- 4~10 Turns to fully open
- Finish - Red RAL3000 or Natural



Part No	MT-451415	MT-451416	MT-451428
Size	DN 50	DN 65	DN 65
Dimensions (mm) W x H	225 x 380	225 x 380	260 x 380
Weight (kg)	10.70	11.50	9.22
Inlet	50mm NP16 BS4504	65mm NP25 BS4504	65mm (2.1/2") BSP or BSPT Male



Licence No. KM 647384

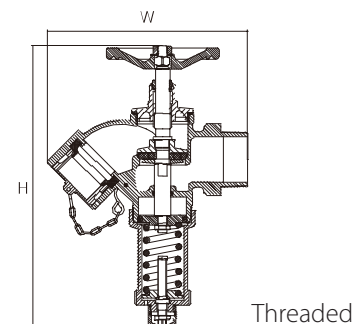
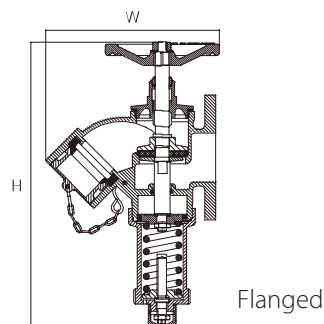

## INTERNATIONAL SALES

**Angus Fire Ltd**  
Angus House, Haddenham Business Park,  
Pegasus Way, Haddenham, Aylesbury, HP17 8LB, UK  
Tel: +44 (0)1844 293600 • Fax: +44 (0)1844 293664

## UK SALES

**Angus Fire Ltd**  
Station Road, Bentham, Lancaster, LA2 7NA, UK  
Tel: +44 (0)1524 264000 • Fax: +44 (0)1524 264180

Angus Fire operates a continuous programme of product development. The right is therefore reserved to modify any specification without prior notice and Angus Fire should be contacted to ensure that the current issues of all technical data sheets are used.

© Angus Fire  
6871/3 07/19