



# ANGUS FIRE

## 12 Kg ABC Dry Powder Gas Cartridge

### Extinguisher



#### Technical Specification

Extinguisher Code	A12G
Extinguishant	ABC Powder. Mono-Ammonium Phosphate and Ammonium Sulphate
Propellant Type	150 gm Gas Cartridge
Capacity	12 kg
Paint Primer/Finish	Polyester Powder Paint
Paint Colour	Signal Red (RAL 3000)
Colour Coding to BS7863	French Blue (RAL 5002)
Fire Class	A, B, C Types + Electrical
Fire Rating	43A/233B
Operating Temperature	-20 to +60°C
Test Pressure	26 Bar
Operating Pressure at 20°C	12 Bar
Discharge Duration	34 sec
Discharge Range	7 m
Cylinder	Mild Steel 1.6mm to EN 10111-DD12
Operating Valve	Diecast Zinc Alloy to EN 1774-Zn A14 (ZL3)
Height	600 mm
Diameter	190 mm
Full Weight	18.7 kg
Empty Weight	5.9 kg
Nominal Carton Size	201 x 201 x 617 mm
Approval	BS EN 3/BAFE



#### Spare Parts

Item	Description	Part No
1	Headcap assembly c/w hose and pick-up tube	MBRH0017
2	Headcap 'O' ring seal	MBRH 0230
3	Safety pin	MBRH 0180
4	Safety pin cap	MBRH 0165
5	Break Tie Indicator	XE 18798
6	Service indicator	MBRH 0185
7	150g cartridge	MC150
-	Wall bracket (not shown)	MBRH 0195
-	Transport bracket and strap (not shown)	MBRH 0314

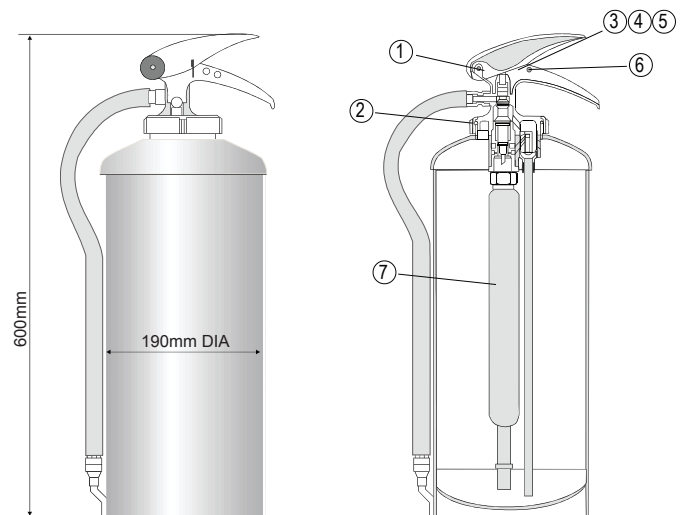

#### INTERNATIONAL SALES

##### Angus Fire Ltd

Angus House, Haddenham Business Park,  
Pegasus Way, Haddenham, Aylesbury, HP17 8LB, UK  
Tel: +44 (0)1844 293600 • Fax: +44 (0)1844 293664

#### UK SALES

##### Angus Fire Ltd

Station Road, Bentham, Lancaster, LA2 7NA, UK  
Tel: +44 (0)1524 264000 • Fax: +44 (0)1524 264180

Angus Fire operates a continuous programme of product development. The right is therefore reserved to modify any specification without prior notice and Angus Fire should be contacted to ensure that the current issues of all technical data sheets are used.

© Angus Fire  
5310/3 02.14