

Tanker Loading Bay Nozzles

Open, Air Aspirating Foam/Water Discharge Nozzles

- Low and High Level versions available
- Compact and robust
- Excellent corrosion resistance



Angus Tanker Loading Bay Nozzles are open, air aspirating Foam/Water discharge nozzles designed for use as part of an engineered fire protection system. Two versions of the nozzle are available.

The K40 nozzle is designed for mounting overhead to protect the top and sides of the road or rail tanker, secure the likely pool fire developing in the surrounding area and provide cooling to the tanker. This K40 nozzle is mounted in a pendant position, has a K factor of 40 and produces a solid cone discharge, of very similar spray patterns with both foam and water.

The K20 LL (Low Level) nozzle is designed for mounting at Low Level to throw foam underneath the vehicle and protect the tyres. The K20 LL nozzle is mounted in an upright position, has a K factor of 20 and produces a truncated triangular shaped discharge.

These K40 and K20 LL nozzles are particularly well suited for use in high risk situations where mixed risk flammable liquids are stored. When used in conjunction with Angus Tankmaster on hydrocarbons or Alcoseal AR-FFFP on solvents and mixed risks both K40 and K20 LL nozzles provide excellent quality of finished foam, sealing off vapours and protecting against re-ignition.

Both K40 and K20 LL nozzles are compact, robust and consequently less easily damaged than conventional designs. Both nozzles are entirely constructed from 316 stainless steel, which provides excellent corrosion resistance.

Both nozzles are designed to produce finished foam with an expansion ratio of 5-7:1 over a 3-7 bar operating range. The K40 nozzle will operate as low as 1 bar when sheltered from the effects of wind.

K40 Nozzle

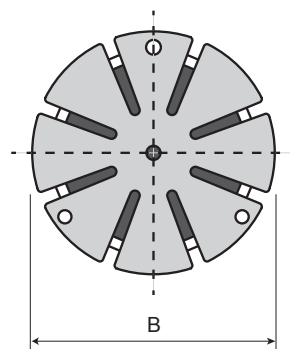

K20 LL Nozzle

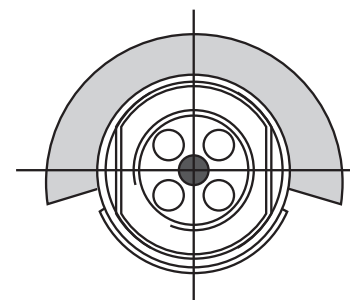
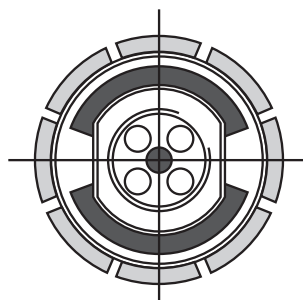
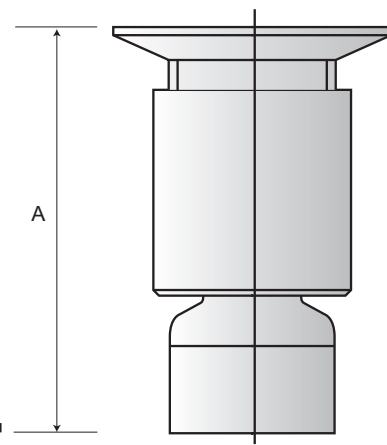
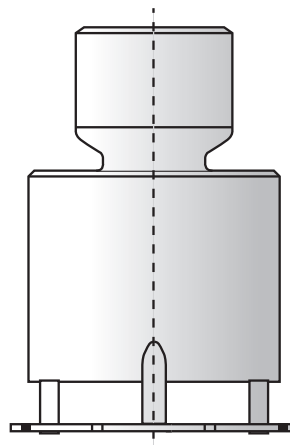
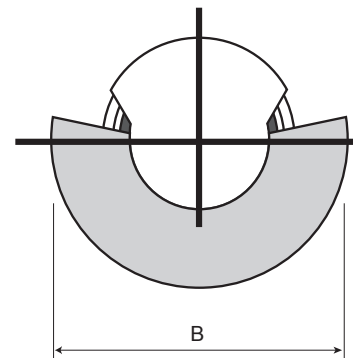



Tanker Loading Bay Nozzles

Open, Air Aspirating Foam/Water Discharge Nozzles

K40 Nozzle Inlet Pressure

Typical K40 print diameter = 3.9 metres at 4 bar when mounted 2.5 metres above ground.

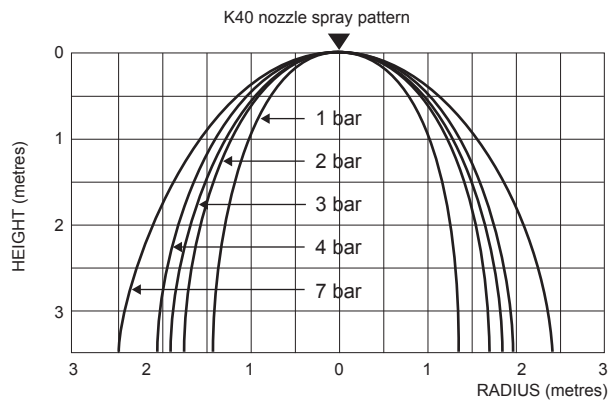

K20 LL Nozzle mounted 0.3m above ground

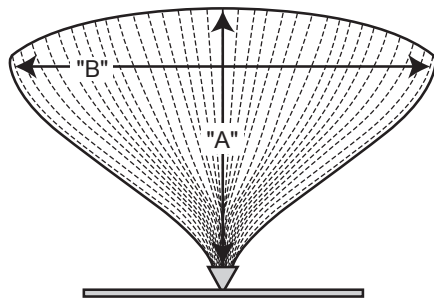

Plan View

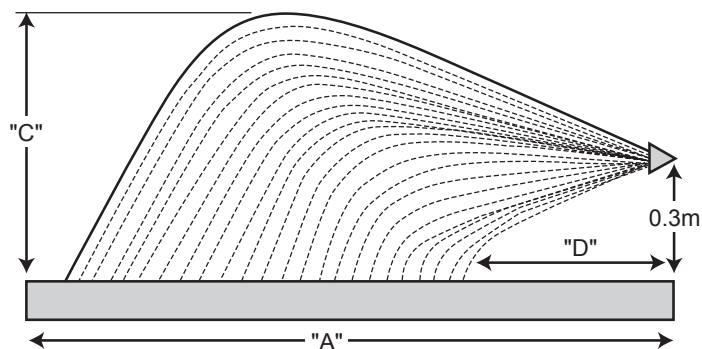

Side View

Typical max throw outwards 5.0 m x max width 5.5m at 5 bar when mounted upright, 0.3 metres above ground.

Performance - K20LL

Foam/Water Sprinklers		
K20 LL Nozzle Inlet pressure Max.	3 bar	5 bar
throw outwards "A" Max. spread/	4.0m	5.0m
width "B"	5.0m	5.5m
Max. height "C"	1.2m	1.5m
Foam distance from nozzle "D"	0.3m	0.3m

Dimensions (nominal)

	K40	K20LL
A (mm)	87.7	113
B (mm)	61 (diameter)	64 (diameter)
Inlet connection	3/4" BSP Female	3/4" BSP Female
Approx. weight	0.41 Kg	0.38 Kg

Angus Fire foam/water stainless steel open spray nozzle mounting orientation

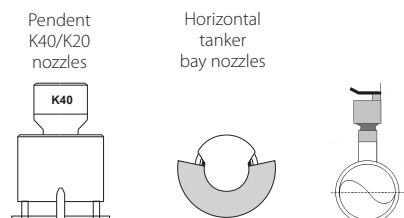

Flow (litres/min) = $K\sqrt{P}$ where P is inlet pressure (bar)

GENERAL SALES

Angus Fire Ltd

Station Road, Bentham, Lancaster, LA2 7NA, UK
Tel: +44 (0)1524 264000 • Fax: +44 (0)1524 264180

Angus Fire operates a continuous programme of product development. The right is therefore reserved to modify any specification without prior notice and Angus Fire should be contacted to ensure that the current issues of all technical data sheets are used.