

Mex Bund Pourers

Angus Medium Expansion (MEX) Bund Pourers

- High performance
- Compact and robust
- Cost-effective



Angus Medium Expansion (MEX) Bund Pourers are designed for fire protection systems and vapour suppression on bunded or diked areas surrounding flammable liquid or toxic chemical storage tanks. They are also suited for other applications requiring large volumes of free flowing foam eg. process areas, warehousing and storage protection.

Storage Tank bund or dike fires, because of their large surface area, are notoriously difficult to control and extinguish. Spillages in these bunded areas are common and have caused several major tank fires.

Significant quantities of unignited fuel can spread rapidly from leaking valves, flanges, cracked pipes, overfill relief systems, boil-overs and even routine maintenance, within the bunded area, threatening personnel and plant safety. Serious incident escalation results from ignition of these flammable vapours.

The most efficient and cost effective way of controlling these risks is with a permanently installed Medium Expansion Bund Pourer system. The high performance Angus MEX Bund Pourer range has been specifically designed to effectively extinguish fires and control vapours in such high risk areas.

The Angus range comprises three lightweight, compact and robust units. Foam solution flows range from 465-1970 litres per minute at inlet pressures of 1.5 to 2.5 bar g. Operation at such low pressure minimises pumping capacities and water requirements, ensuring a cost effective system.

These units are particularly effective when used with Angus fluoroprotein and film forming fluoroprotein foam concentrates (eg FP70 and Alcoséal). Expansion ratios are typically around 25 - 40:1 with a quality fluoroprotein foam at approx. 2.5 bar g. inlet pressure.

Each unit produces a large volume of free flowing stable MEX foam, providing rapid coverage of the bunded area. Such gentle foam application minimises contamination of the foam by the fuel. The cohesive nature of FP/FFFP foams also minimises the effects of wind.

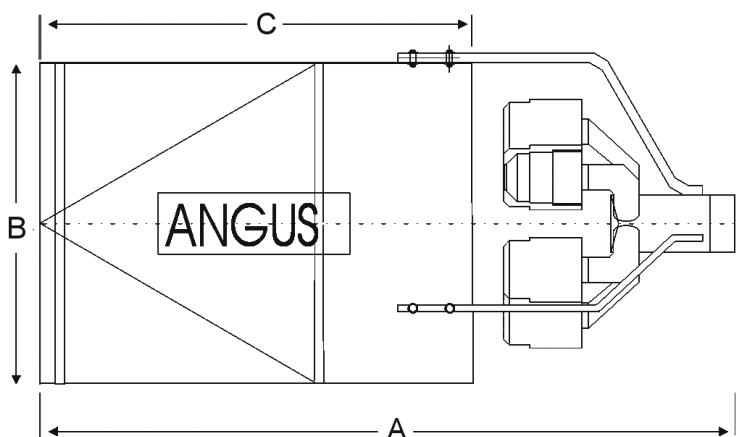



ANGUS FIRE

Mex Bund Pourers

Angus Medium Expansion (MEX) Bund Pourers

Specification						
		MEX 225 FI	MEX 450 FI	MEX 600	MEX 1200	MEX 1800
Nozzle Quantity				3	6	9
Dimensions	A (mm)	410	540	630	905	920
	B (mm)	164	216	300	420	520
	C (mm)	350	475	397	608	648
Inlet Connection		G2 BSP (M)		2" BSP Taper	2½" BSP Taper	3" BSP Taper
Materials	Pipework Spider	Al. Alloy (powder coated)		Carbon Steel - Yellow Thermoplastic Powder Paint Finish		
	Nozzles	Brass, Ni/Cr Plated		Brass/Gunmetal Natural Finish		
Pourer Tube		Stainless Steel to BS970 316S31				
Internals		Stainless Steel to BS970 316S31				
Screws, Nuts, Washers		Stainless Steel A2				
Approximate Weight		1.9 Kg	4.5 Kg	8.5 Kg	16 Kg	24.5 Kg
Performance Data (Typical)						
		MEX 225 FI	MEX 450 FI	MEX 600	MEX 1200	MEX 1800
K Factor*		85	180	380	759	1138
Operating Pressure Range		1.5 - 3.5 bar g		1.5 - 2.5 bar g		
Optimum Flow Rate @ 2.5 bar g Inlet Pressure		104-159 litres/min	220 - 336 litres/min	600 litres/min	1200 litres/min	1800 litres/min
Typical Expansion Ratio (using FP70 @ 6%)**		55 to 1			40:1	
Typical Foam Output @ 2.5 bar g (using FP70 @ 6%)**		8m ³ /min	15m ³ /min	24 m ³ /min	48 m ³ /min	72 m ³ /min

* Flow (litre/min) = K/P where P = pressure in bar g

** Note: FP70 can be used effectively through MEX equipment at 3% proportioning, although optimum foam stability is achieved at 6% proportioning

GENERAL SALES

Angus Fire Ltd

Station Road, Bentham, Lancaster, LA2 7NA, UK
Tel: +44 (0)1524 264000 • Fax: +44 (0)1524 264180

Angus Fire operates a continuous programme of product development. The right is therefore reserved to modify any specification without prior notice and Angus Fire should be contacted to ensure that the current issues of all technical data sheets are used.