

High Back Pressure Foam Generator

Series 2

- For use in sub-surface foam injection systems
- Enhanced performance capabilities
- Choice of models



Angus High Back Pressure Foam Generators (HBPGs) are used in sub-surface foam injection systems which are primarily designed for the protection of fixed roof storage tanks containing hydrocarbon fuels.

The Series 2 generators have significantly enhanced performance capabilities and the range has been extended to nine models, with foam solution capacities from 225 litres/minute to 3300 litres/minute as shown overleaf.

The materials used in construction fully comply with the international standards accepted by the oil and petrochemical industries.

Using a suitable fuel resistant foam concentrate such as Angus Alcoséal, Petroseal and FP70, aspirated foam with an expansion ratio of between 2:1 and 4:1 can be produced against a back pressure of up to 40% of the inlet pressure. This property enables the foam to overcome the pressure exerted by the head of fuel and downstream pipework friction losses.

A non-return valve is fitted as standard to ensure that fuel does not escape from the air inlet hole during any stage of operation and also to ensure that full pressure is available immediately after the system is activated.

Two pressure gauges are fitted to the 225, 450 and 900 models to measure foam solution input pressure and system back pressure which facilitates operation in "semi-fixed" installations. Pressure gauges are optional on the 1400, 1900, 2250, 2650, 2900 and 3300 models.

In addition to any valving on the foam line, a bursting disc assembly is normally installed between the HBPG and the tank to ensure safety integrity. The disc is designed to withstand pressure from the tank side, but to rupture when finished foam from the HBPG reaches a pre-determined pressure. A full range of compatible bursting discs and holders are available.

Approvals

Underwriters Laboratories Inc. :
HBPG 225, HBPG 1400.



For further information on sub-surface foam injection systems, refer to the Angus Foam Systems Engineering Design Manual.

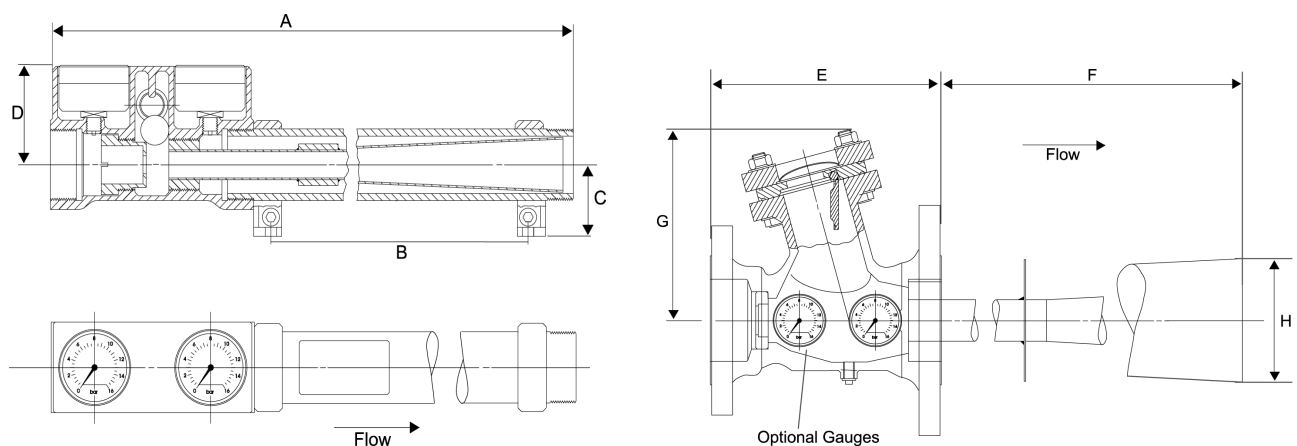

High Back Pressure Foam Generator

Series 2

Specification Data										
Model		HBP225	HBP450	HBP900	HBP1400	HBP1900	HBP2250	HBP2650	HBP2900	HBP3300
Dims	A(mm)	741	751	1135	x	x	x	x	x	x
	B(mm)	505	505	645	x	x	x	x	x	x
	C(mm)	60	60	85	x	x	x	x	x	x
	D(mm)	83	83	106	x	x	x	x	x	x
	E(mm)	x	x	x	280	280	280	280	280	280
	F(mm)	x	x	x	1292	1283	1275	1268	1262	1256
	G(mm)	x	x	x	240	240	240	240	240	240
	H(mm)	x	x	x	150dia	150dia	150dia	150dia	150dia	150dia
	Inlet connection	2" BSP (F)	2" BSP (F)	3" BSP (F)	4" RF Flange to ANSI B 16.5 Class 150					
	Outlet connection	2" BSP (M)	2" BSP (M)	3" BSP (M)	6" RF Flange to ANSI B 16.5 Class 150					
Materials	Body	S.G. Iron -420-12			Cast Steel to ASTM A216 WCB					
	Barrel	Steel			x	x	x	x	x	x
	Nozzle	Acetate			316 Stainless Steel					
	Improver	316 Stainless steel								
Finish		Yellow Thermoplastic powder coated								
Weight (kg)		10	10	22.5	41	41	41	41	41	41

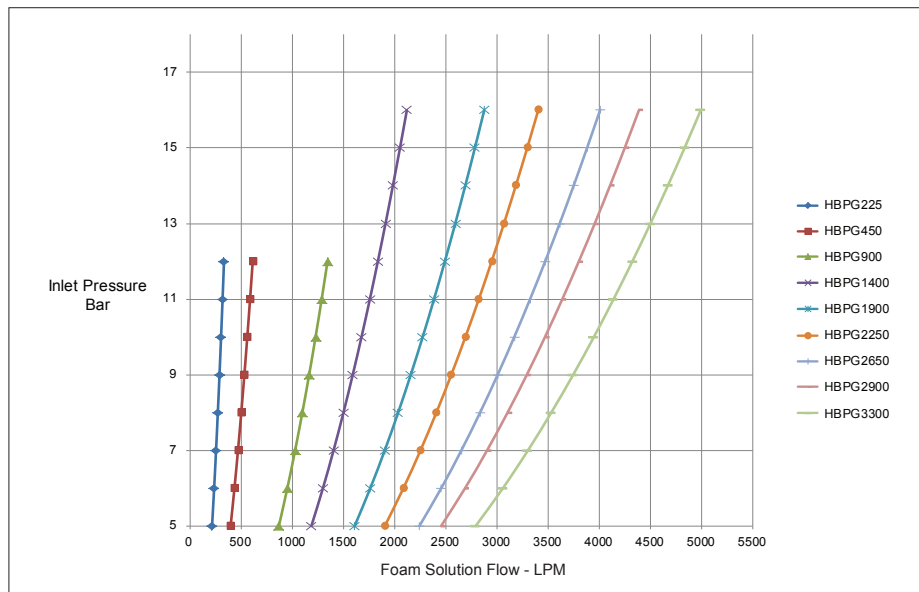

INTERNATIONAL SALES

Angus Fire Ltd
 Angus House, Haddenham Business Park,
 Pegasus Way, Haddenham, Aylesbury, HP17 8LB, UK
 Tel: +44 (0)1844 293600 • Fax: +44 (0)1844 293664

UK SALES

Angus Fire Ltd
 Station Road, Bentham, Lancaster, LA2 7NA, UK
 Tel: +44 (0)1524 264000 • Fax: +44 (0)1524 264180

Angus Fire operates a continuous programme of product development. The right is therefore reserved to modify any specification without prior notice and Angus Fire should be contacted to ensure that the current issues of all technical data sheets are used.